

F114 Ceiling Surface-Mounted Commercial Media Air Cleaner

SPECIFICATION DATA



FEATURES

- Modules available with 99.97% HEPA filters or a combination of 95% DOP particulate filters and CPZ sorbent media modules. The filters in both models are more efficient on particles larger and smaller than 0.3 micron.
- Two-speed, direct-drive, forward curve blowers/motors deliver up to 325 cfm (550 cu m/hr).
- Designed to overcome the increase in airflow resistance normally caused by filter loading.
- Light-colored cover complements most ceiling finishes.
- Models available with CPZ disposable canisters for odor control.

APPLICATION

The F114 Ceiling Surface-Mounted Media Air Cleaner is designed for use in restaurants, conference rooms, lounges and offices where overhead air cleaning is required. The F114 uses direct-drive, forward curve blowers/motors with High Efficiency Particulate Arrestance (HEPA) particulate filters or a combination of 95% DOP (Di-Octyl Phthalate) particulate filters and CPZ™ (Carbon Potassium Permanganate and Zeolite) sorbent media cartridges to remove airborne contaminants. Because the F114 provides its own air circulation, it can be used in any application that requires contamination reduction in an enclosed area.

SPECIFICATIONS

Models:

- F114A Ceiling Surface-Mounted Media Air Cleaner with 99.97% HEPA filters; without CPZ canisters.
- F114C Ceiling Surface-Mounted Media Air Cleaner with 95% DOP filters; with CPZ disposable canisters.

Color:

White grille with white plenum.

Electrical Ratings:

120V, 60 Hz, 1PHS, 3.6A; 220/240V, 50/60 Hz, 1PHS, 1.7A.

Electrical Connections:

J-box hardwired on side and top wired inlet.

Blower/Motor:

Two-speed, direct-drive blower/motor.

Further Information:
BERRIMAN ASSOCIATES
1-800-480-3630
www.berriman.com

F114 CEILING SURFACE-MOUNTED COMMERCIAL MEDIA AIR FILTER

Dimensions:

See Fig. 1.

Weight:

Installed: 40 lb (18 kg).

Controls:

Two-speed On/Off switch.

Sound Level at 3.3 ft (1m):

59 dBA on High speed; 55 dBA on Low speed.

Approvals:

Underwriters Laboratories Inc. Listed.
Canadian Standards Association Certified.

Replacement Parts:

- 32000206 99.97% High Efficiency Particulate Arrestance (HEPA) Filter (2 Required) for F114A1067.
- 32000217 95% DOP Filter (2 Required) for F114C1008.
- 32000229 Prefilters (4 Pack).
- 32000232 Disposable CPZ Cartridge (2 Required).

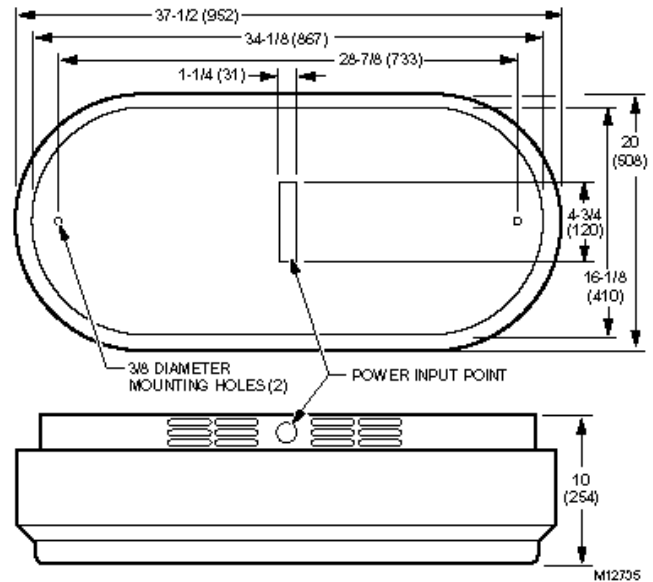

Fig. 1. F114 dimensions In In. (mm).

Further Information:
BERRIMAN ASSOCIATES
1-800-480-3630
www.berriman.com

Honeywell

The Honeywell trademark is used under license from Honeywell Intellectual Properties